

▲EKH-134

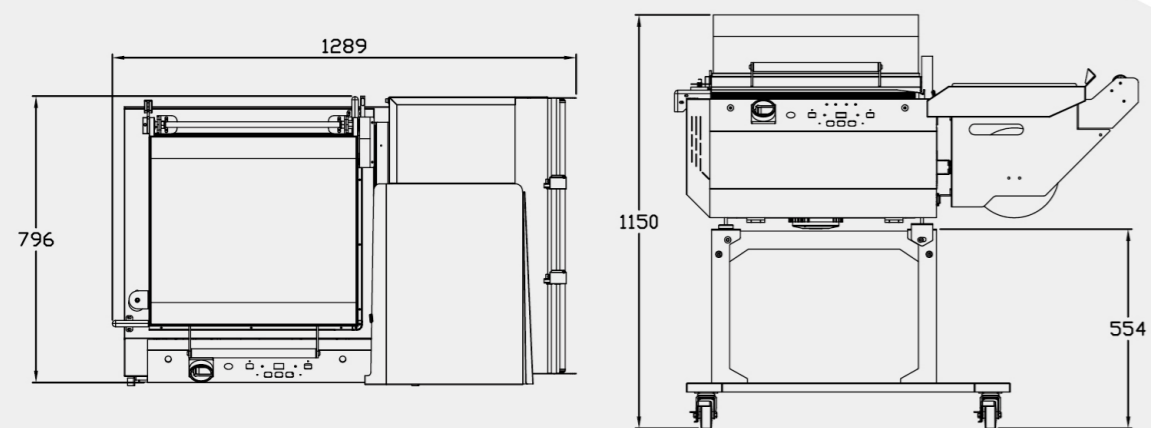

▲EKH-145

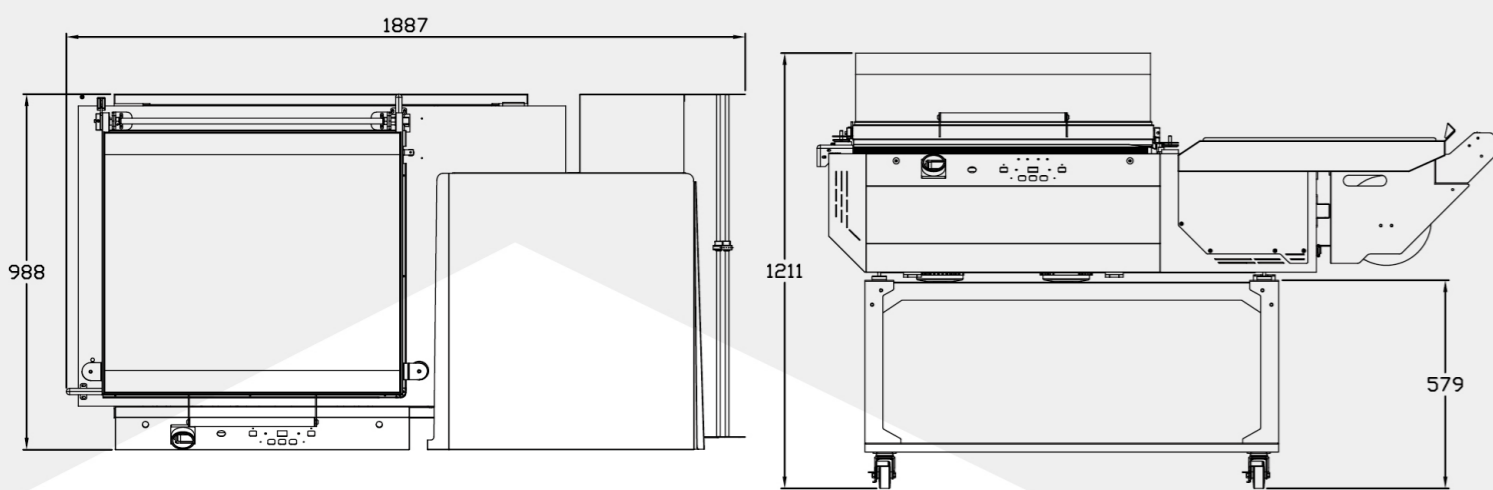

▲EKH-168

# EKHSERIES

EXTEND THE PARTNERSHIP

## EKH-SERIES

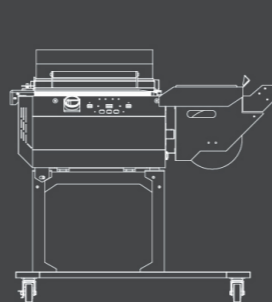

EKH-134

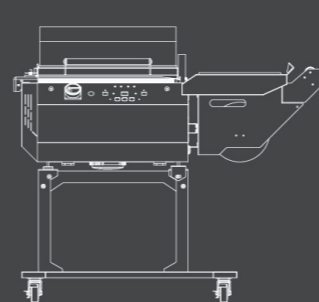

EKH-145

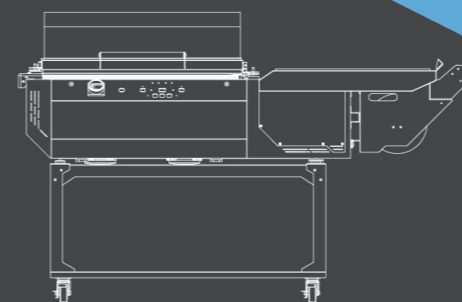

EKH-168

### EXTEND GREAT INTERNATIONAL CORP.

20F., NO. 309, Sec. 2, TAIWAN BLVD.,  
TAICHUNG, TAIWAN, R.O.C.

T 886-4-2326-5568  
F 886-4-2326-2268

www.extendgroup.com.tw  
extend@extendgroup.com.tw

# EKH-134



PATENT PENDING

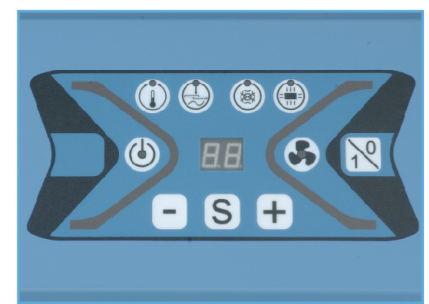

▲CONTROL PANEL

- SPECIFICATION**
- POWER SUPPLY: 110V/220V/230V/240V, 50/60HZ, 1-PHASE
  - MAX. CONSUMPTION POWER: 3.2kW
  - EFFECTIVE POWER CONSUME: 1.3-1.9kW
  - SEALING DIMENSION: 460mm x 335mm
  - MAX. PACKAGING HEIGHT: 210mm
  - MAX. FILM DIMENSION: 400mm x Φ250mm

- OPTIOIN**
- STAND

# EKH-145



PATENT PENDING

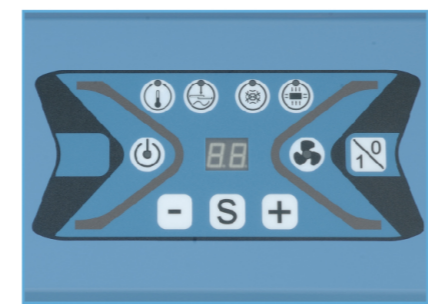

▲CONTROL PANEL

- SPECIFICATION**
- POWER SUPPLY: 220V/230V/240V, 50/60HZ, 1-PHASE
  - MAX. CONSUMPTION POWER: 3.77kW
  - EFFECTIVE POWER CONSUME: 1.6-2.3kW
  - SEALING DIMENSION: 550mm x 415mm
  - MAX. PACKAGING HEIGHT: 300mm
  - MAX. FILM DIMENSION: 600mm x Φ250mm

- OPTIOIN**
- STAND

# EKH-168



PATENT PENDING



▲CONTROL PANEL

- SPECIFICATION**
- POWER SUPPLY: 220V/380V/400V/415V, 50/60HZ, 3-PHASE
  - MAX. CONSUMPTION POWER: 5.3kW
  - EFFECTIVE POWER CONSUME: 2.3-3.4kW
  - SEALING DIMENSION: 800mm x 615mm
  - MAX. PACKAGING HEIGHT: 340mm
  - MAX. FILM DIMENSION: 800mm x Φ250mm

- OPTIOIN**
- STAND
  - ADDITIONAL SOLENOID MAGNETIC